

Oilfreepac® 2000 Standard Oilfreepac® 2000 Superplus Midi (Type 0035 to 0100)

Complete purification package including adsorption dryer, activated carbon adsorber, pre-, afterfilter and condensate drain.

The Oilfreepac® 2000 purification packages are purification units based on adsorption dryers Ultrapac® 2000 to supply clean, dry and oilfree compressed air. Compressed air is led through the inlet of the unit (J) and across the prefilter (2). At this stage, the air is cleaned from particles and condensate.

The condensate is removed via a membrane condensate drain (5). Via the lower shuttle valve (8) the air is led into desiccant cartridges (1) in which the air is dried down to a pressure dew point of -40°C (equivalent to a remaining water content of 0.11 g/m^3). In the following activated carbon purification stage (9) oil vapours, hydrocarbons, taste and odours are adsorbed to a level far below $0,003 \text{ mg/m}^3$.

The final particle filter (3) removes all particles which might be carried over from the adsorption stages. While one vessel with desiccant cartridges is in the drying phase (adsorption), the other cartridge is being dried again (regeneration). A partial stream of dried air is expanded to atmospheric pressure via an orifice (6) and led across the desiccant cartridge for regeneration and via a solenoid valve and a silencer system to atmosphere.



Oilfreepac® 2000 Standard

Oilfreepac® 2000	Volume flow in m^3/h (1 bar, 20°C)*	Reg. air flow average m^3/h (1 bar, 20°C)	Volume flow out (min.) m^3/h (1 bar, 20°C)	Pressure loss initial mbar
0035	35	5,95	27,6	95
0050	50	8,5	39,4	120
0065	65	11,5	51,2	155
0080	80	13,6	63,0	280
0100	100	17	78,8	450

* Related to 1 bar (abs) and 20°C at intake of compressor and 7 bar (g) and 35°C inlet temperature

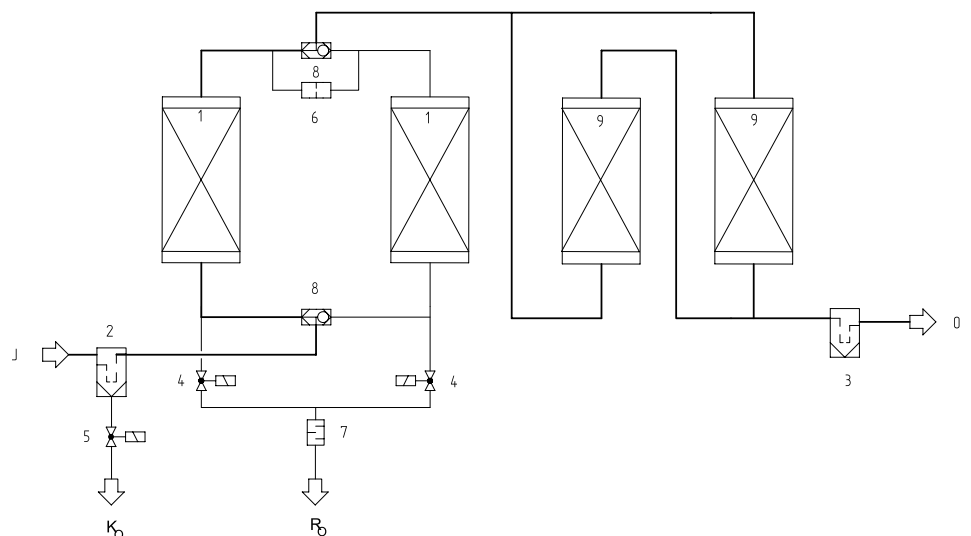

Oilfreepac® 2000 Standard Midi / Superplus Midi

Features Oilfreepac® 2000:	Benefits:
Purification package including adsorption dryer, activated carbon adsorber, pre-, afterfilter and automatic condensate drain	Turnkey system, no additional installation costs; all components from one hand, therefore perfect technical match
Compressed air quality better than on any „oilfree“ installation	Use is highly sensitive production possible (food-, beverage-, electronic industry etc.)
Adsorbent in cartridges	Easy storage, transport and installation; optimum fixation of desiccant; no risk of fluidizing of desiccant.
Compact, space saving design	Installation in smallest spaces, possible also as retrofit
Component exchange display	High operating safety, due to calculation of optimum exchange point for filter elements and desiccant cartridges.
Unique Multifunction Block	All moving parts and all electronic components integrated in a function block, therefore easy and efficient maintenance

Features Oilfreepac® 2000 Superplus:	Benefits:
Intermittent operation standard	Link between dryer and compressor possible on central applications, therefore saving of regeneration air
Load control	Adjustment of adsorption cycles to the actual inlet water load, therefore saving of regeneration air and reduction of operating cost
Self-Diagnosis-System	Sensor-controlled monitoring of regeneration air flow, therefore without-gap-monitoring of dryer functions and of system pressure.
Text Display	Display of all operating status, of fault indication and maintenance intervals in clear text messages
Info-Channel	Serial interface for transmission of alarm- and maintenance messages
Economizer-Function	Online calculation of optimum exchange point of filter elements by continuous evaluation of energy cost versus cost of replacement filter element

Sizing:													
f	4 bar(g)	5 bar(g)	6 bar(g)	7 bar(g)	8 bar(g)	9 bar(g)	10 bar(g)	11 bar(g)	12 bar(g)	13 bar(g)	14 bar(g)	15 bar(g)	16 bar(g)
25°C	0.69	0.82	0.96	1.10	1.24	1.38	1.50	1.50	1.50	1.50	1.50	1.50	1.50
30°C	0.69	0.82	0.96	1.10	1.24	1.38	1.50	1.50	1.50	1.50	1.50	1.50	1.50
35°C	0.63	0.75	0.88	1.00	1.13	1.26	1.38	1.50	1.50	1.50	1.50	1.50	1.50
40°C	0.48	0.58	0.68	0.77	0.87	0.96	1.06	1.16	1.25	1.35	1.45	1.50	1.50
45°C	0.38	0.45	0.53	0.60	0.68	0.75	0.83	0.90	0.98	1.05	1.13	1.20	1.28
50°C	0.30	0.36	0.42	0.48	0.54	0.60	0.66	0.72	0.78	0.84	0.90	0.96	1.02

Example: $\dot{V}_{nom} = 50 \text{ m}^3/\text{h}$, Inlet temperature = 30°C, Operating pressure = 10 bar (g)

$$\dot{V}_{corr} = \frac{\dot{V}_{nom}}{f}$$

$$\dot{V}_{corr} = \frac{50 \text{ m}^3/\text{h}}{1.50} = 33,33 \text{ m}^3/\text{h}$$

Calculated dryer size: Typ 0035

Product description:
Oilfreepac® 2000 Standard and Superplus: Complete purification package including adsorption dryer, activated carbon adsorber, pre-, afterfilter and automatic condensate drain

Medium:
Compressed air

Operation pressure:
min. 4 bar (g), max. 16 bar (g)

Medium temperature:
min. 5 °C, max. 50 °C

Ambient temperature:
min. 4 °C, max. 50 °C

Compressed air consumption:
17% of the rated flow, in average

Power supply:
230 V/50 -60 Hz AC; 110 V/50 -60 Hz AC 24 V DC; 24 V AC on inquiry

Power consumption:
approx. 4 W

Air quality related to standard inlet conditions:	
Particles	< 0.01 mg/m ³
Residual oil content	< 0.01 mg/m ³
Oil vapour and hydrocarbons	< 0.003 mg/m ³
Water vapour	PDP - 40°C (= 0.11 g/m ³)
Taste and odours	taste and odour free

Declaration of conformity:
acc. to 2006/95/EC 97/23/EC

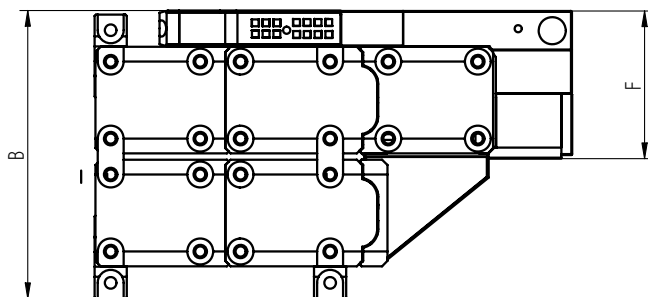
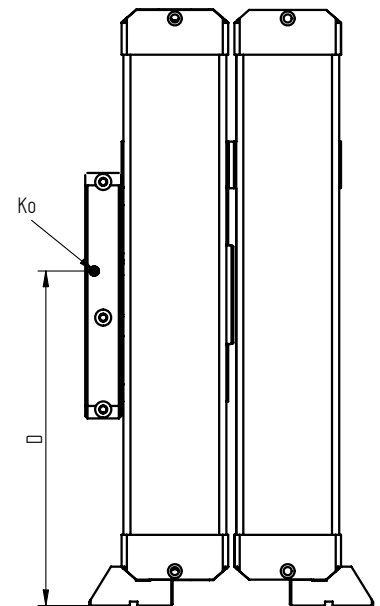
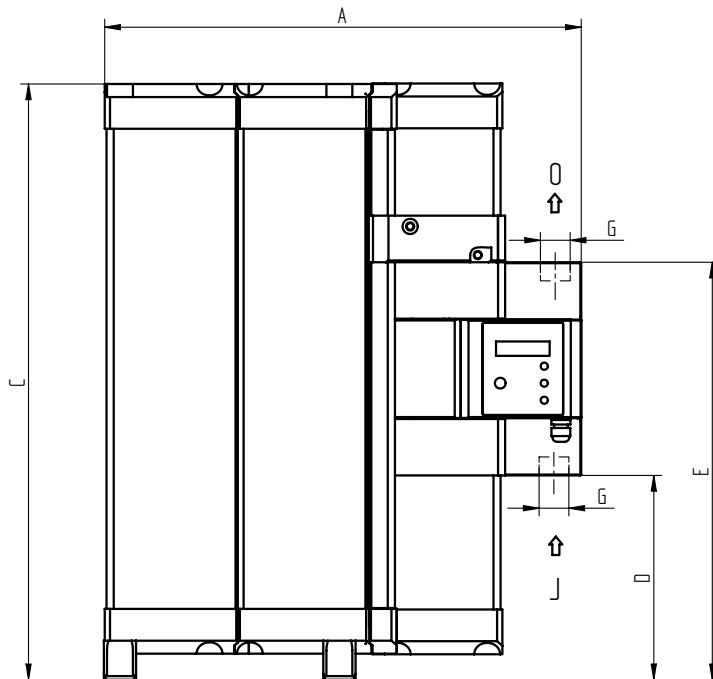
**Oilfreepac[®] 2000 Standard Mini
Oilfreepac[®] 2000 Superplus Mini**

Oilfreepac [®] 2000 - Midi							
Type	G "	A mm	B mm	C mm	D mm	E mm	F mm
0035	G 1	532	322	665	230	465	165
0050	G 1	532	322	920	355	595	165
0065	G 1	532	322	1170	485	720	165
0080	G 1	532	322	1420	605	845	165
0100	G 1	532	322	1670	730	970	165